

FEMALE END VIEW

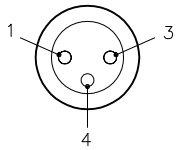

- 1 = BROWN
- 3 = BLUE
- 4 = BLACK



SPECIFICATIONS

CONTACT CARRIER MATERIAL	NYLON
MOLDED HEAD MATERIAL/COLOR	TPU/BLACK
CONTACT MATERIAL/PLATING	BRASS/GOLD
COUPLING NUT MATERIAL/FINISH	STAINLESS STEEL/PASSIVATED
RATED CURRENT [A]	4.0 A
RATED VOLTAGE [V]	125 VAC/VDC
OUTER JACKET MATERIAL/COLOR	PVC/BLACK
CONDUCTOR INSULATION MATERIAL	PVC
NUMBER OF CONDUCTORS [AWG]	3x24 AWG
TEMPERATURE RANGE	-40°C to +105°C (-40°F to +221°F)
PROTECTION CLASS	MEETS NEMA 1,3,4,6P AND IEC IP67

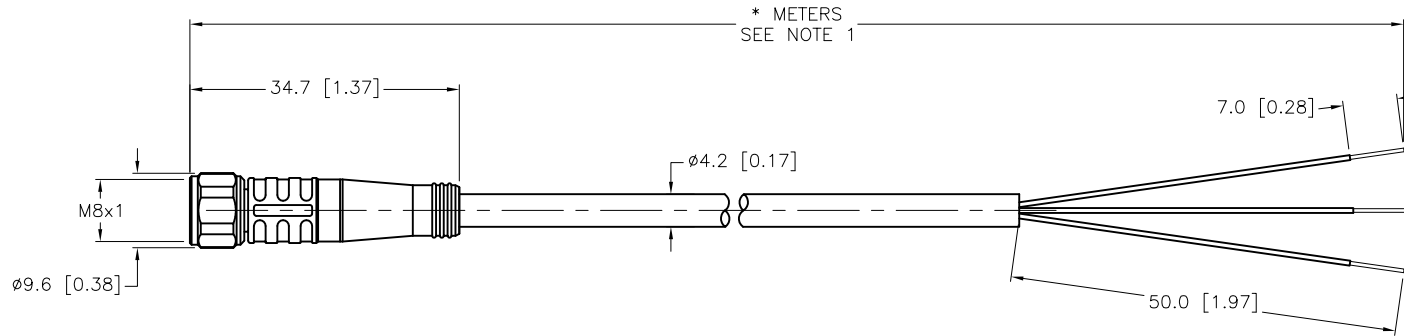

CABLE LENGTH	TOLERANCE
ALL LENGTHS	+ 4% (OR 50mm) OF LENGTH - 0% (OR 0mm) OF LENGTH WHICHEVER IS GREATER
STRIP LENGTH	TOLERANCE
0-7mm	±0.5mm
8-29mm	±1.0mm
30-49mm	±2.0mm
50-69mm	±3.0mm
70-100mm	±4.0mm
OVER 100mm	±5.0mm

SOURCE DRAWING - FOR REFERENCE ONLY

NOTES:

- "*" INDICATES CABLE LENGTH IN METERS. CONTACT TURCK TO ORDER SPECIFIC LENGTHS.
- "/S760" INDICATES BLACK CABLE JACKET.
- "/S771" INDICATES BLACK MOLD BODY.

RELATED DOCUMENTS	3RD ANGLE PROJECTION	THIS DRAWING IS CONFIDENTIAL AND THE PROPERTY OF TURCK INC. USE OF THIS DOCUMENT WITHOUT WRITTEN PERMISSION IS PROHIBITED.		TURCK IAC High Technology Sensors and Automation Controls 3000 CAMPUS DRIVE MINNEAPOLIS, MN 55441 1-800-544-7769 (763) 553-7300 (763) 553-0708 fax turck.com	
1.		DRFT	RDS	DATE	06/11/08
2.		APVD		SCALE	1=1.0
3.	ALL DIMENSIONS DISPLAYED ON THIS DRAWING ARE FOR REFERENCE ONLY	UNIT OF MEASUREMENT		DESCRIPTION	
4.		MILLIMETER [INCH]		PKG 3M-*/S760/S771	
MATERIAL	SEE SPECIFICATIONS	CONTACT TURCK FOR MORE INFORMATION		IDENTIFICATION NO.	
FINISH	SEE SPECIFICATIONS	DO NOT SCALE THIS DRAWING		REV	
				C	
				FILE: 777021964	
				SHEET 1 OF 1	

C	UPDATE CABLE DIAMETER	KMY	02/21/12	37157
REV	DESCRIPTION	BY	DATE	ECO NO.